

## Assembly Instructions for Single Bracket and Rollout Shelf/Drawer/Filing Frame

1) Insert shelf tonks into front and rear slots in both sides at desired height

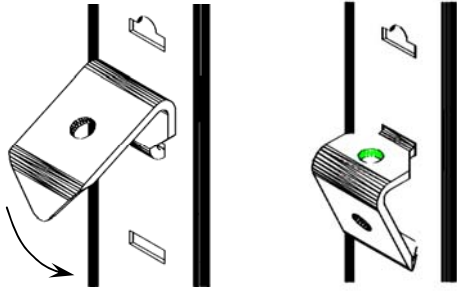

2) Position LH and RH shelf brackets onto shelf tonks

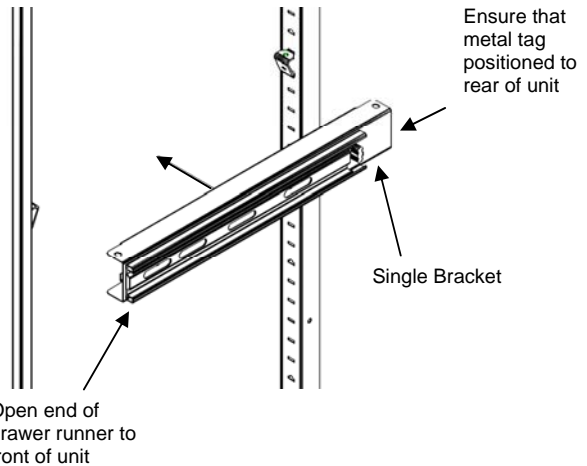

3) Fasten shelf brackets to shelf tonks with M6 bolts (x4) and Allen key provided

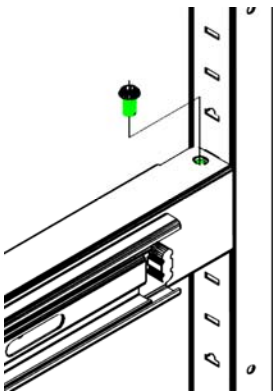

4) It is essential that the centre of the runners on the bracket and rollout fitting are correctly aligned before pushing in rollout fitting

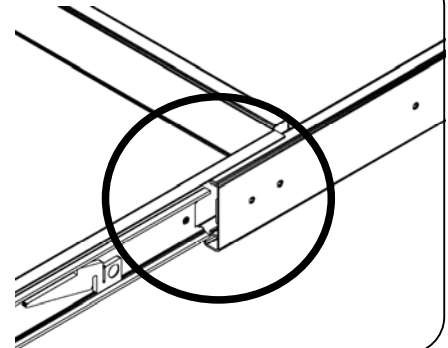

5) Once runners are aligned gently push the centre of the rollout fitting towards unit. Once the fitting has clicked into place, move the fitting backwards and forwards to check it is correctly fitted before using

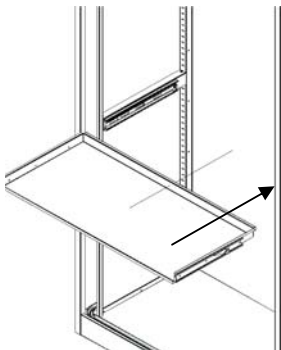

6) To Remove Fitting  
Release levers are fitted to the drawer runners mounted on the rollout. By pressing the 'release levers' on both sides of the fitting together the fitting can be pulled out of the unit.

